



## INSTALLATION, MAINTENANCE, WARRANTY GUIDLNESS



SUNFLEX RECYCLING PVT LTD

### TECHNICAL MANUAL

INSTALLATION ° MAINTAINANCE ° WARRANTY



MANUFACTURE IN INDIA  
[www.sunflexrubberflooring.com](http://www.sunflexrubberflooring.com)

SR NO	MASTER INDEX	PAGE NUMBER
1	MATERIAL STORAGE AND HANDLING	3
2	TOOLS REQUIRE DURING INSTALLATION	4
3	CHECK THE SUB FLOOR	4-5
4	PREPARING/CHECK YOUR SUB FLOOR	5-6
5	INSTALLATION OF STANDARD RUBBER TILES	7
6	INSTALLATION OF INTERLOCKING RUBBER TILES	9
7	CUTTING OF RUBBER TILES	10
8	CHOOSE THE RIGHT ADHESIVE	10-11
9	CLEANING AND MAINTAINANCE	11
10	WARRANTY	13-15

## MATERIAL STORAGE AND HANDLING

- 1) Upon the arrival of material please check whether the material received is correct and not defected.
- 2) Make sure you Inspect the material thoroughly. Report any discrepancy of the original order, defects etc.
- 3) Any defects, size or colour of tiles must be reported to SUNFLEX RECYCLING PVT LTD prior to installation.
- 4) Make sure you store the material on the original package of the company.
- 5) You must open the material gently from the box.
- 6) Store tiles in dry and clean area. Temperature and humidity may cause rubber to expand or contract

**IMPORTANT NOTE: SUNFLEX RECYCLING PVT LTD is not responsible for any labour cost, material or adhesive if the defective material is installed.**

Please read the installation guidelines and warranty before installation of the product.

SUNFLEX RECYCLING PVT LTD product has been checked through several times before dispatching any material.

We recommend that you double check the product order as per your order. If you find any material defective or change as per your order, please report to SUNFLEX RECYCLING PVT LTD immediately before prior installation.

## TOOLS REQUIRE DURING INSTALLATION

Please check the tools required prior to installation for the product.

- 1) Ruler and measurement tape
- 2) Gloves and goggles
- 3) Utility knife and extra blade
- 4) Knee pads
- 5) Chalk line or ball pen
- 6) Hacksaw carbide blade, carpenter's square
- 7) Cleaning tools like towels, vacuum and mop
- 8) Scraping tools like hammer and scraper

For best result we recommend you to hire any technical labour for this particular Installations.

## CHECK THE SUB FLOOR

SUNFLEX RECYCLING PVT LTD tiles can be stick on concrete, asphalt, wood or tile based surface. The information content for subfloor has been best of acknowledge.

	• Recommended / × N/A	INTERIOR APPLICATION
SURFACE	Standard Rubber Tiles	Interlocking Tiles
Concrete	• Recommended	• Recommended
Plywood	• Recommended	• Recommended
Asphalt	× N/A	× N/A
Wood	• Recommended	• Recommended
Tile	• Recommended	• Recommended
Carpet	• Recommended	• Recommended

× N/A- Not an approved Installation Method.

• Recommended / × N/A		EXTERIOR APPLICATION
SURFACE	Standard Rubber Tiles	Interlocking Tiles
Concrete	• Recommended	• Recommended
Compact Gravel	× N/A	× N/A
Asphalt	× N/A	× N/A
Wood	• Recommended	• Recommended
Hard surface tile	• Recommended	• Recommended
Outdoor carpet	• Recommended	• Recommended
Roof Tops	• Recommended	× N/A

× N/A- Not an approved Installation Method.

## PREPARING/CHECK YOUR SUB FLOOR

### Concrete Base

- 1) The contractor shall visit and ascertain the nature of the ground to be excavated and the work to be done and shall accept all responsibility for the cost of the work involved.
- 2) The contractor shall set out the building or other involved works after clearing the site and get sample approved by owner/architects.
- 3) If the new concrete has been made it should be cure for minimum 30 days before installation of SUNFLEX RECYCLING PVT LTD tiles.

- 4) Prior to installation concrete base should be free from dust, oil and free from cracks. The level of sub floor should be free from cracks.
- 5) You must check with contractor for valid license and insurance works.

**IMPORTANT NOTE: SUNFLEX RECYCLING PVT LTD will not be liable for any work done by owner/architects/third person.**

### ASPHALT SURFACE

- 1) Representative samples of all materials proposed for use under these specifications shall be submitted to the engineer for testing. The contractor should also submit this material for testing.
- 2) The contractor shall submit a certified analysis of the proposed asphalt from the testing laboratory to the engineer for review and approval. A copy of the certified analysis shall accompany each shipment of asphalt project.
- 3) The engineer/architects/owner has right to reject the material in accordance with certified analysis.

**IMPORTANT NOTE: SUNFLEX RECYCLING PVT LTD will not be liable for any work done by owner/architects/third person.**

**The rest all subfloor should be acknowledge best with Project engineer, architects or contractor.**

## INSTALLATION OF STANDARD RUBBER TILES

- 1) We recommended you hire any rubber flooring technical labour expert for any installation.
- 2) Make sure you check the floor before installing the rubber tiles
- 3) The surface should be free from dust, oil and grease.
- 4) One may use the hygrometer to check whether the flooring environment has base to dry or not.
- 5) Installation should be done after completing the site.

There are several methods for installation.

- 1) Installation with straight edges

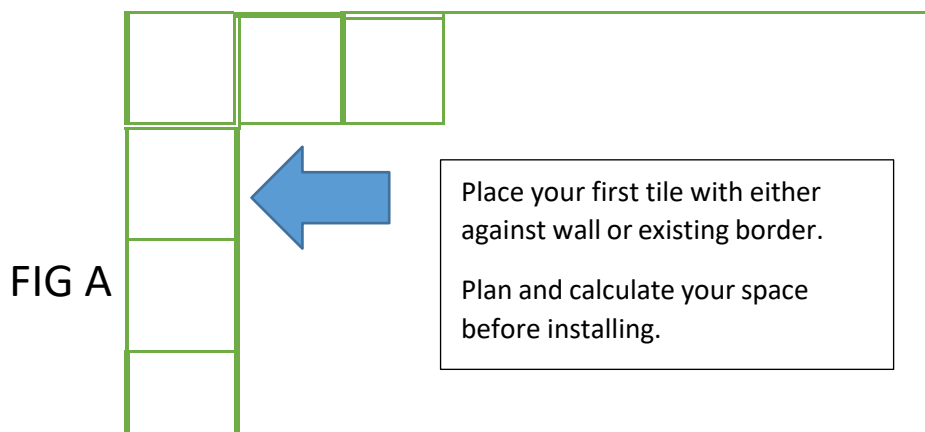

- 1) Make sure you calculate your space before installing the tiles with adhesive or binder.
- 2) Lay the rubber flooring tiles without using adhesive for calculation

- 3) Lay the tiles close to each other, with the minimum gap between them, removing the air while they are being laid, by pressing down gently on tiles.
- 4) Check the work constantly against the guidelines to ensure that edges of the adjacent tiles meet accurately.
- 5) The process may cause slight variance of edges and colour variation from tiles to tiles.

## 2) Installation with perpendicular align of chalk line

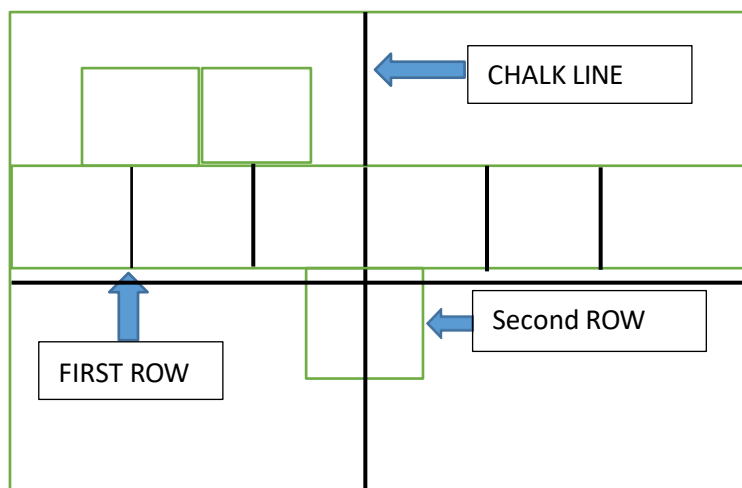

FIGURE B

- 1) Calculate and measure the total area where the installation has been done.
- 2) Splinter or break the area with chalk lines both length & width with center of installation area
- 3) Start with first row of tiles as per chalk line guide
- 4) You should place first row tile at 90° right angle aligned with perpendicular center of chalk lines
- 5) Hence start second row at center of chalk line lining up with middle of tile above as shown in figure B.



## INSTALLATION OF INTERLOCKING RUBBER/ROLL TILES

The interlocking rubber tiles does not require any special type of adhesive or binder to stick.

It's easy to stick and easy to remove. It helps you in safety flooring in few minutes.

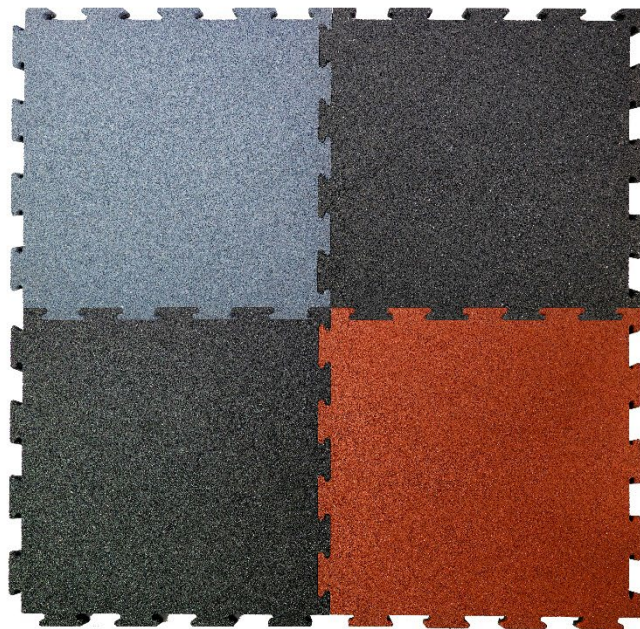

Keep the similar pattern in either right or left direction for best outcome result.

For Installation, please visit below video link.

<https://www.youtube.com/watch?v=l1wAWIUBHc&t=32s>

<https://www.youtube.com/watch?v=SXkGm9t2CR4>

## CUTTING OF RUBBER TILES

- 1) For cutting of tiles you must lay tile on flat surface and hold tiles and cut with sharp utility knife.
- 2) For large size of cutting you must change blade frequently for clean and sharp cuts.
- 3) For best result you can use quality hacksaw tools.
- 4) If the thickness is high as per customize order you may hire another types of cutting tools.

## CHOOSE THE RIGHT ADHESIVE

- 1) You must choose right adhesive for applying square rubber tiles
- 2) Styrene butadiene copolymer (SBR) latex is a type of synthetic rubber adhesive that is durable and highly recommended for commercial and industrial use. Produced from two monomers—butadiene, which is obtained from petroleum, butane, or ethyl alcohol; and styrene, which is obtained from petroleum or benzene - the pressure-sensitive adhesive is extensively used for bonding fibrous materials. SBR adhesives are also known for their excellent bonding strength, highly stable properties, and ability to dry quickly and easily.
- 3) You must wear hand gloves when using adhesive
- 4) You must apply adhesive on sub floor as well as on back side of tiles at every four side and in middle.

- 5) You must allow 48 hours to dry the site without contact of water, traffic or any other works
- 6) Don't place or spill adhesive on the top of tiles as it will destroy the material surface.
- 7) You must check with chemical properties for any pu before installing tiles
- 8) For heavy usage and extreme outdoor application standard sbr adhesive should be used.
- 9) We recommend SUNFLEX PU for outdoor application

For Indoor you we recommend you to use DOW Polyurethane Adhesive Voramer RR 1009 or 1008 or similar brand with specification available globally.

## CLEANING AND MAINTAINANCE



### 1) INITIAL CLEANING

- Remove all loose debris and dust and any residual sand with broom or vacuum.
- Clean the floor covering with a PH neutral detergent using a mop or a combined wash/vacuum machine in larger areas.

- In case of heavy dirt, clean the flooring using a low speed mono brush equipped with light abrasive disc (red disc in the 3M scale) and PH neutral detergent. Wet vacuum, rinse several times and leave to dry.

## 2) DAILY MAINTENANCE

- Remove dust, dirt and stains from the floor.
- Clean with a broom and damp cloth or mop, a micro-fibre mop or vacuum may also be used. If detergent is required always use a PH neutral product. A combined machine with PH neutral detergents is suggested in larger areas.

## 3) PERIODIC MAINTENANCE

- When standard maintenance operations are not sufficient to remove dirt, a deeper cleaning is recommended in order to restore the initial appearance of the flooring.
- In case of heavy dirt, clean the flooring using a low speed mono brush equipped with light abrasive disc (red disc in the 3M scale) and PH neutral detergent. Wet vacuum, rinse several times and leave to dry.
- If necessary, restore the desired level of gloss using a spray-buffing system. The speed of the machine and the type of detergent/floor maintainer is to be selected depending on the level of dirt and on the desired level of gloss. Contact us for more details.



## WARRANTY

**SUNFLEX RECYCLING PVT LTD will offer limited one-year warranty against original purchaser of Rubber tiles with terms and condition apply. This limited warranty is subject to the following conditions:**

**The Warranty is apply to all products of SRPL.**

The limited warranty will continue for one year from the date of purchase as documented by a purchase receipt from the Original Purchaser. "Original Purchaser" applies to the first purchaser and specifically **excludes distributors and/or dealers.**

Claims must be sent in writing to Warranty Claims at SUNFLEX RECYCLING PVT LTD corporate registered office within 30 days from the date of original purchase. Proof of purchase will be required.

Sunflex Rubber has right to inspect or test any defective material or product prior to replacement.

**SUNFLEX RECYCLING PVT LTD has right to revoke the warranty claims.**

This limited warranty shall not apply if the Original Purchaser denies SUNFLEX RECYCLING PVT LTD and its representatives access to the installed products and/or fails to cooperate in providing permission for this access.

**Excluded from the warranty.**

The exact matching of shade, colour, or colour distribution.  
Any express or implied promise made by any salesman or representative.

Labour costs including, without restriction, cost of initial installation, cost of removal and/or cost of replacement of defective tiles.

Problems or damage caused by mold and mildew growth.  
The fading of the colours for epdm rubber granules, surface cracks & penetrations.

The exact range of the granules size for epdm rubber granules.

Repairs, alterations or modifications made to the surfaces without prior consultation or consent of SUNFLEX RECYCLING PVT LTD.

Problems caused by uses, maintenance and installation that is contrary to specifications, recommendations or instructions by SUNFLEX RECYCLING PVT LTD.

Problems caused by failure to install product on a flat, hard surface.

Problems caused by adding attachments or parts not sold by SUNFLEX RECYCLING PVT LTD

Fading and/or discoloration resulting from sunlight penetrations and ultraviolet ray exposure.

Problems or damage caused by natural disasters.

## DISCLAIMER

SUNFLEX RECYCLING PVT LTD tiles has been made 100% from recycled used tires. The used tires have mix range of truck, car, otr tires.

Hence size of the crumb granules of tiles may varies from batch to batch as per last orders. Hence this recycle process may get variation from tiles to tiles. It may effect tiles edges, colour variation and granules of rubber tiles.

The element properties of car and truck tyres crumb may vary creating the batch change when heating or colour dye, hence effected in effect tiles edges, colour variation and granules of rubber tiles.

**IMPORTANT NOTE: SUNFLEX RECYCLING PVT LTD has right to revoke the warranty claims.**